

# **Safety and operating instructions**

**Handheld hydraulic breakers**

**BRK 25, 40, 55, 70, 95**

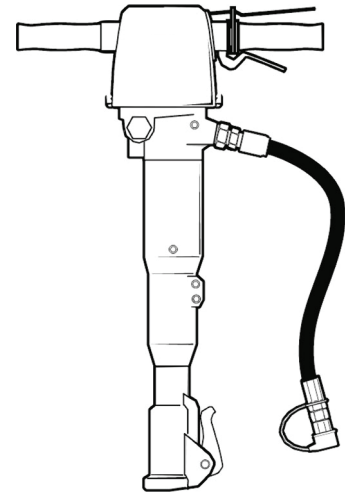



# Contents

<b>Introduction</b> .....	5
<b>About the Safety and operating instructions</b> .....	5
<b>Safety instructions</b> .....	6
Safety signal words.....	6
Personal precautions and qualifications.....	6
Installation, precautions.....	6
Operation, precautions.....	7
Maintenance, precautions.....	10
Storage, precautions.....	10
<b>Overview</b> .....	11
Design and function.....	11
Main parts.....	11
Choosing the correct breaker for a task.....	11
Labels.....	11
<b>Installation</b> .....	12
Hoses.....	12
Quick-release couplings.....	13
Hydraulic oil.....	13
Nipple.....	13
Insertion tool.....	14
<b>Operation</b> .....	15
Start and stop.....	15
Operating.....	15
When taking a break.....	17
<b>Maintenance</b> .....	17
Every day.....	17
Every week.....	17
Every three month.....	17
Every 600 hours of operation or every year.....	17
<b>Storage</b> .....	17
<b>Disposal</b> .....	18
<b>Technical data</b> .....	19
Troubleshooting.....	19
Machine data.....	19
Noise and vibration declaration statement.....	21
Noise and vibration data.....	22
<b>EC Declaration of Conformity</b> .....	25
EC Declaration of Conformity (EC Directive 2006/42/EC).....	25



## Introduction

Thank you for choosing Chicago Pneumatic brand products. For over a century, the Chicago Pneumatic brand has represented performance and innovation in the pneumatic tool industry.

Today the brand is found around the world on a range of pneumatic and hydraulic tools that includes breakers, rock drills, chipping hammers, clay-diggers, picks and busters, scabblers, pumps and a whole lot more.

The Chicago Pneumatic brand is associated with powerful and reliable products that are easy to maintain and that give good value for the money.

For more information please visit [www.cp.com](http://www.cp.com)

Atlas Copco Construction Tools AB  
105 23 Stockholm  
Sweden

## About the Safety and operating instructions

The aim of the instructions is to provide you with knowledge of how to use the hydraulic breaker in an efficient, safe way. The instructions also give you advice and tell you how to perform regular maintenance on the hydraulic breaker.

Before using the hydraulic breaker for the first time you must read these instructions carefully and understand all of them.

## Safety instructions

To reduce the risk of serious injury or death to yourself or others, read and understand the Safety and operating instruction before installing, operating, repairing, maintaining, or changing accessories on the machine.

Post this Safety and operating instruction at work locations, provide copies to employees, and make sure that everyone reads the Safety and operating instruction before operating or servicing the machine.

In addition, the operator or the operator's employer must assess the specific risks that may be present as a result of each use of the machine.

## Safety signal words

The safety signal words Danger, Warning and Caution have the following meanings:

<b>DANGER</b>	Indicates a hazardous situation which, if not avoided, will result in death or serious injury.
<b>WARNING</b>	Indicates a hazardous situation which, if not avoided, could result in death or serious injury.
<b>CAUTION</b>	Indicates a hazardous situation which, if not avoided, could result in minor or moderate injury.

## Personal precautions and qualifications

Only qualified and trained persons may operate or maintain the machine. They must be physically able to handle the bulk, weight, and power of the tool. Always use your common sense and good judgement.

### Personal protective equipment

Always use approved protective equipment. Operators and all other persons in the working area must wear protective equipment, including at a minimum:

- > Protective helmet
- > Hearing protection
- > Impact resistant eye protection with side protection
- > Respiratory protection when appropriate
- > Protective gloves
- > Proper protective boots
- > Appropriate work overall or similar clothing (not loose-fitting) that covers your arms and legs.

### Drugs, alcohol or medication

#### ▲ **WARNING** Drugs, alcohol or medication

Drugs, alcohol or medication may impair your judgment and powers of concentration. Poor reactions and incorrect assessments can lead to severe accidents or death.

- ▶ Never use the machine when you are tired or under the influence of drugs, alcohol or medication.
- ▶ No person who is under the influence of drugs, alcohol or medication may operate the machine.

## Installation, precautions

#### ▲ **WARNING** Ejected insertion tool

If the tool retainer on the machine is not in a locked position, the inserted tool can be ejected with force, which can cause personal injury.

- ▶ Never start the machine while changing the insertion tool.
- ▶ Before changing the insertion tool or accessories, stop the machine, switch off the power supply and bleed the machine by activating the start and stop device.
- ▶ Never point the inserted tool at yourself or anyone else.
- ▶ Make sure that the insertion tool is fully inserted and the tool retainer is in a locked position before the machine is started.
- ▶ Check the locking function by pulling the inserted tool outwards forcefully.

#### ▲ **WARNING** Moving or slipping insertion tool

An incorrect dimension of the inserted tool's shank can result in that the inserted tool is lost or is slipping out during operation. Risk of severe injury or crushed hands and fingers.

- ▶ Check that the insertion tool has the shank length and dimensions that the machine is intended for.
- ▶ Never use an insertion tool without a collar.

#### ▲ **DANGER** Compressed gas, explosion hazard

The accumulator is pressurized even when the hydraulic system is shut off. To dismount the accumulator without first releasing the nitrogen gas can cause serious personal injury or death.

- ▶ Fill the high-pressure accumulator with nitrogen (N<sub>2</sub>) only.
- ▶ Only authorised personnel are qualified to work with the accumulator.

**▲ WARNING Hydraulic oil at high pressure**

Thin jets of hydraulic oil under high pressure can penetrate the skin and cause permanent injury.

- ▶ Immediately consult a doctor if hydraulic oil has penetrated the skin.
- ▶ Never use your fingers to check for hydraulic fluid leaks.
- ▶ Keep your face away from any possible leaks.

**▲ WARNING Hydraulic oil**

Spilled hydraulic oil can cause burns, accidents due to slippery conditions and will also harm the environment.

- ▶ Take care of all spilled oil and handle it according to your safety and environmental regulations.
- ▶ Never dismount the hydraulic machine when the hydraulic oil is hot.
- ▶ Never run any hydraulic lines for attachment of the hydraulic machine through the drivers cab.

**▲ CAUTION Skin eczema**

Hydraulic oil can cause eczema if it comes in contact with the skin.

- ▶ Avoid getting hydraulic oil on your hands.
- ▶ Always use protective gloves when working with hydraulic oil.
- ▶ Wash hands after contact with hydraulic oil.

**▲ CAUTION Moving parts**

Risk for crushed hands and fingers.

- ▶ Never check bores or passages with hands or fingers.

## **Operation, precautions**

**▲ DANGER Explosion hazard**

If an insertion tool comes into contact with explosives or explosive gases, an explosion could occur. When working on certain materials and when using certain materials in machine parts, sparks and ignition can occur. Explosions will lead to severe injuries or death.

- ▶ Never operate the machine in any explosive environment.
- ▶ Never use the machine near flammable materials, fumes or dust.
- ▶ Make sure that there are no undetected sources of gas or explosives.

**▲ WARNING Operating pressure**

If the maximum operating pressure for the hydraulic machine is exceeded, the accumulator can be over charged which can result in material damage and personal injury.

- ▶ Always run the hydraulic machine with the correct operating pressure. See "Technical data".

**▲ WARNING Unexpected movements**

The inserted tool is exposed to heavy strains when the machine is used. The inserted tool may break due to fatigue after a certain amount of use. If the inserted tool breaks or gets stuck, there may be sudden and unexpected movement that can cause injuries. Furthermore, losing your balance or slipping may cause injury.

- ▶ Make sure that you always keep a stable position with your feet as far apart as your shoulder width, and keeping a balanced body weight.
- ▶ Always inspect the equipment prior to use. Never use the equipment if you suspect that it is damaged.
- ▶ Make sure that the handles are clean and free of grease and oil.
- ▶ Keep your feet away from the inserted tool.
- ▶ Stand firmly and always hold on to the machine with both hands.
- ▶ Never start the machine when it is lying on the ground.
- ▶ Never 'ride' on the machine with one leg over the handle.
- ▶ Never strike or abuse the equipment.
- ▶ Check regularly for wear on the insertion tool, and check whether there are any signs of damage or visible cracks.
- ▶ Pay attention and look at what you are doing.

**▲ WARNING Dust and fume hazard**

Dusts and/or fumes generated or dispersed when using the machine may cause serious and permanent respiratory disease, illness, or other bodily injury (for example, silicosis or other irreversible lung disease that can be fatal, cancer, birth defects, and/or skin inflammation).

Some dusts and fumes created by drilling, breaking, hammering, sawing, grinding and other construction activities contain substances known to the State of California and other authorities to cause respiratory disease, cancer, birth defects, or other reproductive harm. Some examples of such substances are:

- > Crystalline silica, cement, and other masonry products.
- > Arsenic and chromium from chemically-treated rubber.
- > Lead from lead-based paints.

Dust and fumes in the air can be invisible to the naked eye, so do not rely on eye sight to determine if there is dust or fumes in the air.

To reduce the risk of exposure to dust and fumes, do all of the following:

- ▶ Perform site-specific risk assessment. The risk assessment should include dust and fumes created by the use of the machine and the potential for disturbing existing dust.
- ▶ Use proper engineering controls to minimize the amount of dust and fumes in the air and to minimize build-up on equipment, surfaces, clothing, and body parts. Examples of controls include: exhaust ventilation and dust collection systems, water sprays, and wet drilling. Control dusts and fumes at the source where possible. Make sure that controls are properly installed, maintained and correctly used.
- ▶ Wear, maintain and correctly use respiratory protection as instructed by your employer and as required by occupational health and safety regulations. The respiratory protection must be effective for the type of substance at issue (and if applicable, approved by relevant governmental authority).
- ▶ Work in a well ventilated area.
- ▶ If the machine has an exhaust, direct the exhaust so as to reduce disturbance of dust in a dust filled environment.
- ▶ Operate and maintain the machine as recommended in the operating and safety instructions

- ▶ Select, maintain and replace consumables/ inserted tools/ other accessory as recommended in the operating and safety instructions. Incorrect selection or lack of maintenance of consumables/ inserted tools/ other accessories may cause an unnecessary increase in dust or fumes.
- ▶ Wear washable or disposable protective clothes at the worksite, and shower and change into clean clothes before leaving the worksite to reduce exposure of dust and fumes to yourself, other persons, cars, homes, and other areas.
- ▶ Avoid eating, drinking, and using tobacco products in areas where there is dust or fumes.
- ▶ Wash your hands and face thoroughly as soon as possible upon leaving the exposure area, and always before eating, drinking, using tobacco products, or making contact with other persons.
- ▶ Comply with all applicable laws and regulations, including occupational health and safety regulations.
- ▶ Participate in air monitoring, medical examination programs, and health and safety training programs provided by your employer or trade organizations and in accordance with occupational health and safety regulations and recommendations. Consult with physicians experienced with relevant occupational medicine.
- ▶ Work with your employer and trade organization to reduce dust and fume exposure at the worksite and to reduce the risks. Effective health and safety programs, policies and procedures for protecting workers and others against harmful exposure to dust and fumes should be established and implemented based on advice from health and safety experts. Consult with experts.
- ▶ Residues of hazardous substances on the machine can be a risk. Before undertaking any maintenance on the machine clean it thoroughly.

**▲ WARNING Projectiles**

Failure of the work piece, of accessories, or even of the machine itself may generate high velocity projectiles. During operating, splinters or other particles from the working material may become projectiles and cause personal injury by striking the operator or other persons. To reduce these risk:

- ▶ Use approved personal protective equipment and safety helmet, including impact resistant eye protection with side protection.
- ▶ Make sure that no unauthorised persons trespass into the working zone.
- ▶ Keep the workplace free from foreign objects.
- ▶ Ensure that the work piece is securely fixed.



**▲ WARNING Splinters hazard**

Using the insertion tool as a hand struck tool can result in splinters hitting the operator and can cause personal injury.

- ▶ Never use an insertion tool as a hand struck tool. They are specifically designed and heat-treated to be used only in a machine.

**▲ WARNING Slipping, tripping and falling hazards**

There is a risk of slipping or tripping or falling, for example tripping on the hoses or on other objects. Slipping or tripping or falling can cause injury. To reduce this risk:

- ▶ Always make sure that no hose or other object is in your way or in any other person's way.
- ▶ Always make sure you are in a stable position with your feet as far apart as your shoulders width and keeping a balanced body weight.

**▲ WARNING Motion hazards**

When using the machine to perform work-related activities, you may experience discomfort in the hands, arms, shoulders, neck, or other parts of the body.

- ▶ Adopt a comfortable posture whilst maintaining secure footing and avoiding awkward off-balanced postures.
- ▶ Changing posture during extended tasks may help avoid discomfort and fatigue.
- ▶ In case of persistent or recurring symptoms, consult a qualified health professional.

**▲ WARNING Vibration hazards**

Normal and proper use of the machine exposes the operator to vibration. Regular and frequent exposure to vibration may cause, contribute to, or aggravate injury or disorders to the operator's fingers, hands, wrists, arms, shoulders and/or nerves and blood supply or other body parts, including debilitating and/or permanent injuries or disorders that may develop gradually over periods of weeks, months, or years. Such injuries or disorders may include damage to the blood circulatory system, damage to the nervous system, damage to joints, and possibly damage to other body structures.

If numbness, persistent recurring discomfort, burning sensation, stiffness, throbbing, tingling, pain, clumsiness, weakened grip, whitening of the skin, or other symptoms occur at any time, when operating the machine or when not operating the machine, stop operating the machine, tell your employer and seek medical attention. Continued use of the machine after the occurrence of any such symptom may increase the risk of symptoms becoming more severe and/or permanent.

Operate and maintain the machine as recommended in these instructions, to prevent an unnecessary increase in vibration.

The following may help to reduce exposure to vibration for the operator:

- ▶ Let the tool do the job. Use a minimum hand grip consistent with proper control and safe operation.
- ▶ If the machine has vibration absorbing handles, keep them in a central position, avoid pressing the handles into the end stops.
- ▶ When the percussion mechanism is activated, the only body contact with the machine you should have are your hands on the handle or handles. Avoid any other contact, for example supporting any part of the body against the machine or leaning onto the machine trying to increase the feed force. It is also important not to keep the start and stop device engaged while extracting the tool from the broken work surface.
- ▶ Make sure that the inserted tool is well-maintained (including sharpness, if a cutting tool), not worn out, and of the proper size. Insertion tools that are not well-maintained, or that are worn out, or that are not of the proper size result in longer time to complete a task (and a longer period of exposure to vibration) and may result in or contribute to higher levels of vibration exposure.
- ▶ Immediately stop working if the machine suddenly starts to vibrate strongly. Before resuming the work, find and remove the cause of the increased vibrations.
- ▶ Never grab, hold or touch the inserted tool when using the machine.

- ▶ Participate in health surveillance or monitoring, medical exams and training programs offered by your employer and when required by law.
- ▶ When working in cold conditions wear warm clothing and keep hands warm and dry.
- ▶ The exhaust air is strongly chilled and shall not make contact with the operator. Always direct the exhaust air away from hands and body.

See the "Noise and vibration declaration statement" for the machine, including the declared vibration values. This information can be found at the end of these Safety and operating instructions.

#### **▲ DANGER Electrical hazard**

The machine is not electrically insulated. If the machine comes into contact with electricity, serious injuries or death may result.

- ▶ Never operate the machine near any electric wire or other source of electricity.
- ▶ Make sure that there are no concealed wires or other sources of electricity in the working area.

#### **▲ WARNING Concealed object hazard**

During operating, concealed wires and pipes constitute a danger that can result in serious injury.

- ▶ Check the composition of the material before operating.
- ▶ Watch out for concealed cables and pipes for example electricity, telephone, water, gas and sewage lines etc.
- ▶ If the inserted tool seems to have hit a concealed object, switch off the machine immediately.
- ▶ Make sure that there is no danger before continuing.

#### **▲ WARNING Involuntary start**

Involuntary start of the machine may cause injury.

- ▶ Keep your hands away from the start and stop device until you are ready to start the machine.
- ▶ Learn how the machine is switched off in the event of an emergency.
- ▶ Stop the machine immediately in all cases of power supply interruption.

#### **▲ WARNING Noise hazard**

High noise levels can cause permanent and disabling hearing loss and other problems such as tinnitus (ringing, buzzing, whistling, or humming in the ears). To reduce risks and prevent an unnecessary increase in noise levels:

- ▶ Risk assessment of these hazards and implementation of appropriate controls is essential.
- ▶ Operate and maintain the machine as recommended in these instructions.
- ▶ Select, maintain and replace the insertion tool as recommended in these instructions.
- ▶ If the machine has a silencer, check that it is in place and in good working condition.
- ▶ Always use hearing protection.
- ▶ Use damping material to prevent work pieces from 'ringing'.

## **Maintenance, precautions**

#### **▲ WARNING Machine modification**

Any machine modification may result in bodily injuries to yourself or others.

- ▶ Never modify the machine. Modified machines are not covered by warranty or product liability.
- ▶ Always use original parts, insertion tools, and accessories.
- ▶ Change damaged parts immediately.
- ▶ Replace worn components in good time.

#### **▲ CAUTION Hot machine**

The insertion tool and the machine can become hot during use. Touching it can lead to burns.

- ▶ Never touch a hot insertion tool or machine.
- ▶ Wait until the insertion tool and the machine has cooled down before carrying out maintenance work.

#### **▲ WARNING Insertion tool hazards**

Accidental engagement of the start and stop device during maintenance or installation can cause serious injuries, when the power source is connected.

- ▶ Never inspect, clean, install, or remove the insertion tool while the power source is connected.

## **Storage, precautions**

- ◆ Keep the machine and tools in a safe place, out of the reach of children and locked up.

## Overview

**To reduce the risk of serious injury or death to yourself or others, read the Safety instructions section found on the previous pages of this manual before operating the machine.**

## Design and function

Handheld hydraulic breakers are sturdy and reliable breakers designed for working together with Chicago Pneumatic hydraulic power packs or, by means of a Chicago Pneumatic OFD oil flow divider, with most hydraulic excavators, backhoe loaders and tractors.

There are no limitations on the ambient temperature at the work place as long as the hydraulic fluid used keeps within its operational parameters.

The handheld breakers are available in many different sizes with varying impact energies and commonly used tool sizes. The handheld breakers are designed for various jobs from light brickwork and asphalt jobs to heavy duty jobs in reinforced concrete. No other use is permitted. To choose the correct insertion tool, see the spare part list or accessories catalogue.

All handheld breakers are delivered with tail-hoses with Flat-Face quick-release couplings for easy connection to the Chicago Pneumatic power packs.

## Main parts

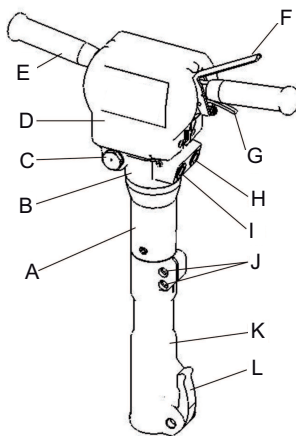

- A. Striking mechanism
- B. Valve housing
- C. Sockets
- D. Accumulator (inside)
- E. Handles
- F. Trigger
- G. Safety trigger

- H. Outlet oil
- I. Inlet oil
- J. Screws
- K. Front body
- L. Latch

## Choosing the correct breaker for a task

It is important to choose the correct size of breaker for the work to be performed.

A breaker that is too small means that the work will take longer.

A breaker that is too large means that there must be frequent repositioning, which is unnecessarily tiring for the operator.

A simple rule for choosing the correct size of breaker is that a normal sized piece of broken material should be removed from the workpiece within 10–20 seconds operation.

- > If it takes less than 10 seconds a smaller breaker should be selected.
- > If it takes more than 20 seconds a larger breaker should be selected.

## Labels

The machine is fitted with labels containing important information about personal safety and machine maintenance. The labels must be in such condition that they are easy to read. New labels can be ordered from the spare parts list.

**Data plate**

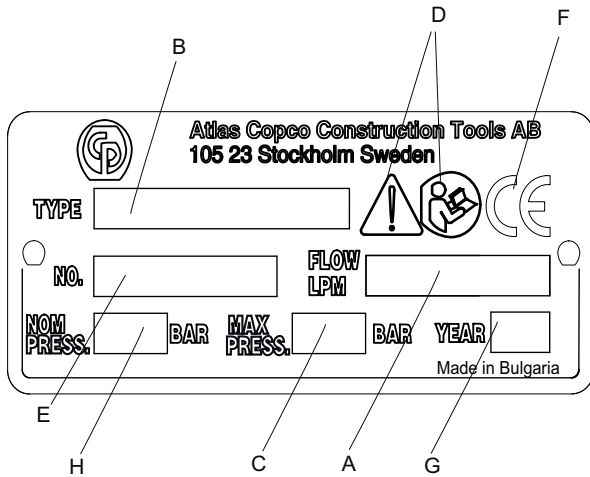

- A. Maximum permitted hydraulic oil flow
- B. Machine type
- C. Maximum relief valve setting
- D. The warning symbol together with the book symbol means that the user must read the safety and operating instructions before the machine is used for the first time.
- E. Serial number (is also stamped in the valve housing).
- F. The CE symbol means that the machine is EC-approved. See the EC declaration which is delivered with the machine for more information.
- G. Year of manufacture.
- H. Maximum nominal operating pressure

**Noise level label**

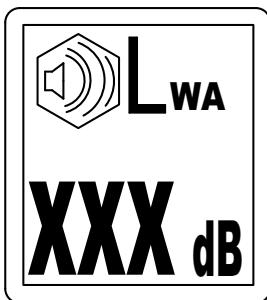

The label indicates the guaranteed noise level corresponding to EC-directive 2000/14/EC. See "Technical data" for accurate noise level.

**Accumulator**



The accumulator must only be charged with Nitrogen.

**NOTICE** Only certified personnel are allowed to work with the accumulator.

**EHTMA category**

The machine is clearly marked with EHTMA categories. It is important that any power source used is in a compatible category. If any doubt, consult an authorised supervisor.



**Safety label**



**Installation**

**▲ WARNING Whipping hydraulic hose**

Hydraulic hoses under pressure can whip uncontrollably if screws loosen or are loosened. A whipping hydraulic hose can cause severe injuries.

- ▶ Depressurise the hydraulic system before loosening the connection of a hydraulic hose.
- ▶ Tighten the nuts on the connections of the hydraulic hoses to the required torque.
- ▶ Check that the hydraulic hose and the connections are not damaged.

**Hoses**

For connection on the machine, the hydraulic hose must be approved for a working pressure of at least 172 bar (2,500 psi) and have a 12.7 mm (½ in.) inner diameter. To resist exterior wear and tear, we recommend using a 2-layer hydraulic hose. The machine connection marked P (pump) is the oil inlet,

and the connection marked T (tank) is the oil outlet. Always connect both hoses and make sure that all hose connections are tight. Never carry the machine by the hose.

## Quick-release couplings

The original hydraulic hoses are fitted with Flat-Face quick-release couplings that are strong and easy to clean. The quick-release couplings are fitted so that the male connection supplies oil and the female connection receives oil.

**NOTICE** Wipe all couplings clean before connecting. Ensure that couplings are clean and correctly engaged before operation. Failure to do so may result in damage to the quick couplings and cause overheating and cause foreign matter to enter the hydraulic system.

## Hydraulic oil

In order to protect the environment, Chicago Pneumatic recommends the use of biologically degradable hydraulic oil. No other fluids must be used.

- ◆ Viscosity (preferred) 20-40 cSt.
- ◆ Viscosity (permitted) 15-100 cSt.
- ◆ Viscosity index Min. 100.

Standard mineral or synthetic oil can be used. Make sure to only use clean oil and filling equipment.

When the machine is used continuously, the oil temperature will stabilise at a level which is called the working temperature. This will, depending on the type of work and the cooling capacity of the hydraulic system, be between 20-40°C (68-104°F) above the ambient temperature. At working temperature, the oil viscosity must lie within the preferred limits. The viscosity index indicates the connection between viscosity and temperature. A high viscosity is therefore preferred, because the oil can then be used within a wider temperature range. The machine must not be used, if oil viscosity fails to remain within the permitted area, or if the working temperature of the oil does not fall between 20°C (68°F) and 70°C (158°F).

## Nipple

At delivery, breakers BRK 25 D, BRK 40 and BRK 40 VR are factory set to 20 l.p.m (EHTMA C). They can not be adjusted to a higher flow. BRK 55, BRK 55 VR, BRK 55 HBP, BRK 55 VR HBP, BRK 70, BRK 70 VR, BRK 70 HBP and BRK 70 VR HBP are supplied factory set to 30 l.p.m (EHTMA D). There is a plastic bag in the

package with a label and restrictor nipple that should be mounted on the tank line (T) if there is a need for the breaker to be set to 20 l.p.m. The size of the orifice is stamped on the nipple. BRK 95 and BRK 95 VR are supplied factory set to 30 l.p.m (EHTMA D). They also have a plastic bag in the package with a label and a nipple with no restrictor if there is a need for the breaker to be operated at 40 l.p.m (EHTMA E).

There is also a possibility for the breakers to be set to intermediate flows (25 l.p.m and 35 l.p.m) as specified in the table below. The nipples needed for these settings are not supplied with the breaker, they have to be ordered from the spare parts list.

BRK 95 HBP is supplied factory set to 30 l.p.m (EHTMA D).

	Oil flow rate				
	20 l.p.m	25 l.p.m	30 l.p.m	35 l.p.m	40 l.p.m
BRK 25 D	no restrictor	-	-	-	-
BRK 40	no restrictor	-	-	-	-
BRK 40 VR	no restrictor	-	-	-	-
BRK 55	restrictor 3.4	restrictor 4.2	no restrictor	-	-
BRK 55 VR	restrictor 3.4	restrictor 4.2	no restrictor	-	-
BRK 70	restrictor 3.4	restrictor 4.2	no restrictor	-	-
BRK 70 VR	restrictor 3.4	restrictor 4.2	no restrictor	-	-
BRK 95	-	-	restrictor 4.2	restrictor 5.2	no restrictor
BRK 95 VR	-	-	restrictor 4.2	restrictor 5.2	no restrictor
BRK 95 HBP	-	-	restrictor 5.2	-	-

	Oil flow rate			
	20 l.p.m Back Pressure <10bar	20 l.p.m Back Pressure 10-35 bar	30 l.p.m Back Pressure <10bar	30 l.p.m Back Pressure 10-35 bar
BRK 55 HBP	restrictor 2.8	restrictor 3.2	restrictor 3.4	no restrictor
BRK 55 VR HBP	restrictor 2.8	restrictor 3.2	restrictor 3.4	no restrictor
BRK 70 HBP	restrictor 2.8	restrictor 3.2	restrictor 3.2	no restrictor
BRK 70 VR HBP	restrictor 2.8	restrictor 3.2	restrictor 3.2	no restrictor

There is no EHTMA category for the intermediate flows.

### Replacing the nipple

1. Disconnect the breaker from the power source.
2. Fix the breaker in vertical position in a vice or in another way so that the breaker is fixed. Never place it on the nose part because the breaker can tilt.
3. Loosen the fitting on the T-hose. Remember to have an oil pan ready to take the oil spill from the breaker. Drain the oil from the T-hose into the oil pan.
4. Loosen the nipple on the breaker. Remember to have an oil pan ready to take the oil spill from the breaker.
5. Move the seal from the old nipple to the new nipple. Apply Loctite 245 and fit the nipple. Tighten with a torque of  $56 \pm 2$  Nm.
6. Refit the hose.
7. Replace the existing EHTMA label, on the breaker with the new one from the plastic bag, so that it can be seen that the breaker is now set to a different flow.
8. Connect the breaker to the power source and check it for leakage.

## Insertion tool

### ▲ CAUTION Hot insertion tool

The tip of the insertion tool can become hot and sharp when used. Touching it can lead to burns and cuts.

- ▶ Never touch a hot or sharp insertion tool.
- ▶ Wait until the insertion tool has cooled down before carrying out maintenance work.

**NOTICE** Never cool a hot insertion tool in water, it can result in brittleness and early failure.

### Selecting the right insertion tool

Selecting the right insertion tool is a precondition for proper machine function. It is important to select insertion tools of high quality to avoid unnecessary machine damage.

The machine can be destroyed if you use an incorrect insertion tool.

Recommended insertion tools are listed in the machine's spare parts list.

### Narrow chisel

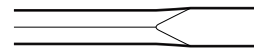

The narrow chisel is used for demolition and cutting work in concrete and other types of hard materials.

### Moil point

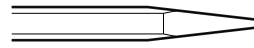

The moil point is only used for making holes in concrete and other types of hard materials.

### Wide bladed chisel

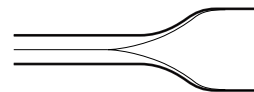

The wide bladed chisel is used in soft materials, such as asphalt and frozen ground.

### ▲ WARNING Vibration hazard

Using inserted tools that do not fulfil the criterias mentioned below, will result in a longer time to complete a task, and may result in higher levels of vibration exposure. A worn tool will also cause increased working time.

- ▶ Make sure that the inserted tool is well-maintained, not worn out and of the proper size.
- ▶ Always use a sharp tool in order to work efficiently.

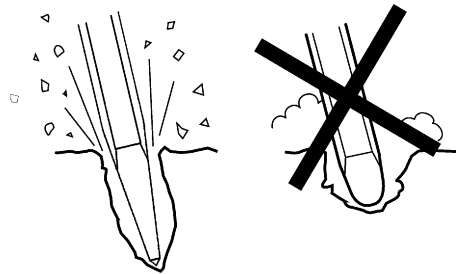

### Checking for wear on the tool shank

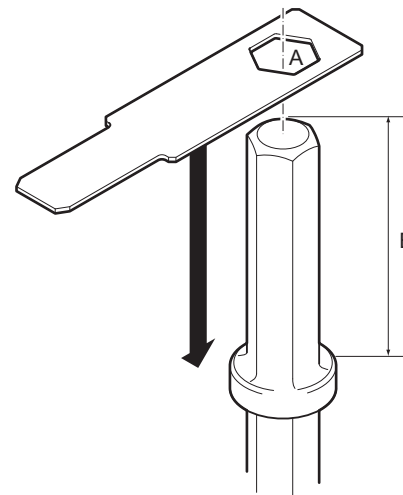

Use the gauge that corresponds to the insertion tool's shank dimension. See section "Technical data" for correct tool shank dimensions.

- > Check if the gauge's hole (A) can be pushed down on the insertion tool's shank, this means that the shank is worn out and the insertion tool should be replaced.
- > Check the length (B), that it is according to the ordered machine type.

### Fitting and removing the insertion tool

Whenever fitting or removing the insertion tool the following instructions must be observed:

1. To prevent an accidental start: switch off the power supply and bleed the machine by pressing the start and stop device. Disconnect the machine from the power source.
2. Before inserting a tool, lubricate the tool shank with grease.
3. Fit or remove the insertion tool.
4. Close the tool retainer (position A) and check the lock function by tugging the inserted tool sharply outwards.

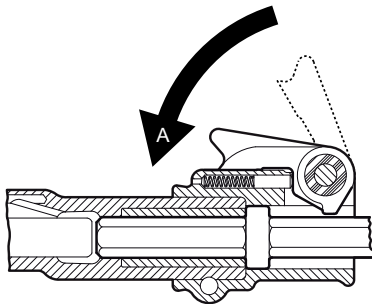

## Operation

### ▲ WARNING Involuntary start

Involuntary start of the machine may cause injury.

- ▶ Keep your hands away from the start and stop device until you are ready to start the machine.
- ▶ Learn how the machine is switched off in the event of an emergency.
- ▶ Stop the machine immediately in all cases of power supply interruption.

## Start and stop

### Start

- > Check that the tool is in good order and pressed fully home in the nose of the breaker.
- > Check that the latch is locked, so that the tool does not fall out.
- > Remove the protective caps from the quick-release couplings.
- > Clean the quick-release couplings if needed and connect the tail-hoses to the extension hoses of the power source.
- > Place the breaker at a right angle on the material to be broken and activate the trigger lever.

### Stop

- > Release the trigger. Press the breaker against the surface, until the breaker has stopped completely.
- > Stop the power source.
- > Disconnect the hoses and fit the protective caps to the quick-release couplings.

## Operating

### Preparation before starting

The following checks should be made each time you start to use the breaker. All these checks concern the serviceability of the breaker. Some concern your safety:

- ◆ Clean all safety stickers. Replace any that are missing or cannot be read.
- ◆ Inspect the hoses generally for signs of damage.
- ◆ Inspect the working tool for wear and damage. Do not use an excessively worn or damaged tool.
- ◆ Connect the tool.
- ◆ Ensure that the hydraulic couplings are clean and fully serviceable.
- ◆ Never invert the breaker without first isolating it from the power source. The working tool might be ejected violently while connecting it, if the breaker is connected to the power source.
- ◆ Ensure that any power source you plan to use is compatible with the breaker model used (see the "Technical data"). Use the recommended oil flow divider, if the flow from the power source can exceed the maximum allowed oil flow.
- ◆ Never exceed the maximum relief valve setting stated on the tool.

- ◆ Always connect T and P hoses before starting.

### Starting a cut

- ◆ Stand in a stable position with your feet well away from the inserted tool.
- ◆ Press the machine against the working surface before you start.
- ◆ Start collaring at such a distance from the edge that the machine is capable of breaking the material without leverage.
- ◆ Never break off too large pieces. Adjust the breaking distance (A) so that the inserted tool does not get stuck.

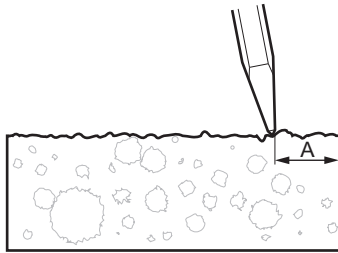

### Breaking

- ◆ Let the machine do the work; do not press too hard. The vibration-reducing handle must absolutely not be pressed all the way down to the base.
- ◆ Hydraulic breakers with vibration-reducing handles: The feed force should be adapted so that the handles are pressed down 'half way'. The best vibration damping and breaking effect is achieved at this position.

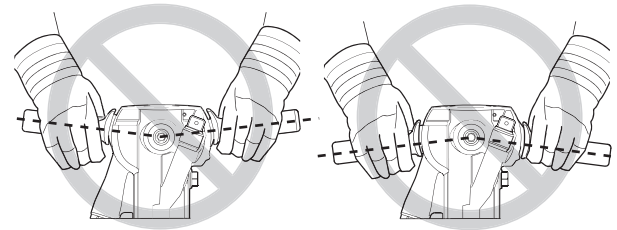
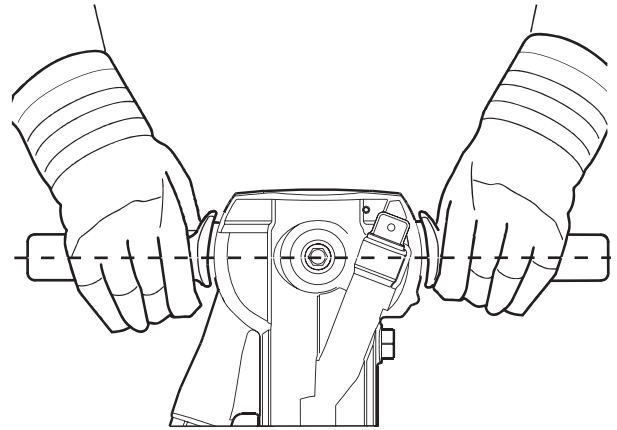

- ◆ Avoid working in extremely hard materials for example granite and reinforcing iron (re-bar) which would cause substantial vibrations.
- ◆ Any form of idling, operating without insertion tool or operating with an uplifted machine must be avoided.
- ◆ When the machine is lifted, the start and stop device must not be activated.
- ◆ Check regularly that the machine is well lubricated.
- ◆ Never use the machine as a hand held impact tool.
- ◆ Ensure that the work piece is securely fixed.



## When taking a break

---

- ◆ During all breaks you must place the machine in such a way that there is no risk for it to be unintentionally started. Make sure to place the machine on the ground, so that it can not fall.
- ◆ In the event of a longer break or when leaving the workplace: Switch off the power supply and then bleed the machine by activating the start and stop device.

## Maintenance

Regular maintenance is a basic requirement for the continued safe and efficient use of the machine. Follow the maintenance instructions carefully.

- ◆ Before starting maintenance on the machine, clean it in order to avoid exposure to hazardous substances. See "Dust and fume hazards"
- ◆ Use only authorised parts. Any damage or malfunction caused by the use of unauthorised parts is not covered by warranty or product liability.
- ◆ When cleaning mechanical parts with solvent, comply with appropriate health and safety regulations and ensure there is satisfactory ventilation.
- ◆ For major service of the machine, contact the nearest authorised workshop.
- ◆ After each service, check that the machine's vibration level is normal. If not, contact the nearest authorised workshop.

## Every day

---

- ◆ Clean and inspect the machine and its functions each day before the work commences.
- ◆ Check the tool retainer for wear and function.
- ◆ Conduct a general inspection for leaks and damage and wear.
- ◆ For the machine to maintain the specified vibration values, always check the following:  
Too big a clearance between the insertion tool's shank and the chisel bushing will generate increased vibrations. To avoid exposure to excessive vibrations, check the chisel bushing for wear every day.
- ◆ Check that the handle is moving freely (up and down) and does not jam.

- ◆ Change damaged parts immediately.
- ◆ Replace damaged and worn components in good time.
- ◆ Make sure that all the attached and related equipment, such as hoses and flow dividers are properly maintained.

## Every week

---

- ◆ Check that the springs are not damaged.

## Every three month

---

- ◆ Check tightness of nuts, bolts, screws and hose fittings. When retightening see the correct torque settings in the spare part list.
- ◆ Check the bushing in the nose for wear and damage.
- ◆ If the breaker is equipped with Ergonomic handles check the adjustment of the handles. When the trigger lever is pressed fully down you should be able to move the trigger pawl (with a screwdriver) approximately 1 millimetre further.

## Every 600 hours of operation or every year

---

- ◆ Check moving parts, seals and bolts for wear and cracks. Replace if necessary.
- ◆ Check the function of the machine.

## Storage

- ◆ Disconnect the machine's hoses from the power source, see "Start and stop".
- ◆ Make sure that the machine is properly cleaned before storage.
- ◆ In case of long-term storage, the striking piston must be protected against corrosion. This is done by pushing it (through the bushing) to its upper position while the machine is placed up-side-down. As the quick-release couplings are blocked when disconnected, the striking piston must be pushed upwards with the hoses mounted but the power pack inactivated.
- ◆ Store the machine in a dry place.

## Disposal

A used machine must be treated and scrapped in such a way that the greatest possible portion of the material can be recycled and any negative influence on the environment is kept as low as possible.

Before a used machine is scrapped it must be emptied and cleaned from all hydraulic oil. The remaining hydraulic oil must be deposited and any negative influence on the environment is to be kept as low as possible.

## Technical data

## Troubleshooting

Problem	Cause	Solution
Breaker does not work. Pressure is not built up when trigger is activated	No or incorrect flow/pressure	Check flow/pressure by means of test equipment
	P and T hoses interchanged	Check connection. Standard connection has oil flowing from male quick-release coupling (i.e. the tail-hose of the breaker P connection is fitted with female coupling)
	Insufficient activation of trigger valve	Adjust trigger lever (if adjustable) or replace defective parts
Breaker does not work. Pressure is built up when trigger is activated	Diaphragm failed	Dismount, check and replace seals
	Back pressure too high	Make direct tank connection. Max. back pressure 10-15 bar (150-200 psi) measured at breaker
	Quick-release coupling in return line defective	Locate and replace defective coupling
	Striking piston sticks, possibly due to thickening of cylinder	<ul style="list-style-type: none"> <li>&gt; Push the breaker hard against the working tool</li> <li>&gt; Chamfer/polish the edge slightly at the cylinder dashpot (where the cylinder bore changes size)</li> <li>&gt; Check oil viscosity. Thin oil increases the risk of thickening</li> </ul>
	Spool/reversing spool or auxiliary spool sticking	Dismount and check that all parts move easily. Polish slightly if necessary
Breaker runs weakly or irregularly	Seals defective	Dismount, check and replace
	Insufficient flow	Check flow/pressure
	Seals defective	Replace seals
Hoses pulsate	Wear, internal leakage	<ul style="list-style-type: none"> <li>&gt; Dismantle, check and replace defective or worn parts</li> <li>&gt; Check oil for impurities and oil viscosity at working temperature</li> <li>&gt; Thin oil = increased internal leakage</li> </ul>
	Accumulator defective	Replace accumulator diaphragm and charge with nitrogen
	Seals defective	Replace seals
Oil leaking from breaker	Seals defective	Replace seals
Working tool falls out	Worn latch	Replace latch and roll pins
	Worn chisel bushing or tool	Replace bushing or tool

## Machine data

	Shank dimension (mm)	Weight (kg)	Length (mm)	Impact freq. (Hz)	Accumulator pressure (bar)	Operating pressure (bar)	Flow rate (l/m)	EHTMA Category
BRK 25 D	22 x 82.5	12.6	600	40	40	70-90	18-22	C
BRK 40	25 x 108	17.5	640	27	40	95-115	18-22	C
	28 x 160	19	690	27	40	95-115	18-22	C
	32 x 152	19	690	27	40	95-115	18-22	C
	32 x 160	19	690	27	40	95-115	18-22	C
BRK 40 VR	25 x 108	22	650	27	40	95-115	18-22	C
	28 x 152	23.5	700	27	40	95-115	18-22	C
	32 x 152	23.5	700	27	40	95-115	18-22	C
	32 x 160	23.5	700	27	40	95-115	18-22	C
BRK 55	25 x 108	20.5	680	25-33	50	110-125	18-30	D (C)
	28 x 160	22	730	25-33	50	110-125	18-30	D (C)
	32 x 152	22	730	25-33	50	110-125	18-30	D (C)
	32 x 160	22	730	25-33	50	110-125	18-30	D (C)
BRK 55 VR	25 x 108	25	690	25-33	50	110-125	18-30	D (C)

	Shank dimension (mm)	Weight (kg)	Length (mm)	Impact freq. (Hz)	Accumulator pressure (bar)	Operating pressure (bar)	Flow rate (l/m)	EHTMA Category
	28 x 160	26.5	735	25-33	50	110-125	18-30	D (C)
	32 x 152	26.5	735	25-33	50	110-125	18-30	D (C)
	32 x 160	26.5	735	25-33	50	110-125	18-30	D (C)
BRK 55 HBP	25 x 108	20.5	680	25-33	50	110-140	18-30	D (C)
	28 x 152	22	730	25-33	50	110-140	18-30	D (C)
	32 x 152	22	730	25-33	50	110-140	18-30	D (C)
BRK 55 VR HBP	25 x 108	25	690	25-33	50	110-140	18-30	D (C)
	28 x 152	26.5	735	25-33	50	110-140	18-30	D (C)
	28 x 160	26.5	735	25-33	50	110-140	18-30	D (C)
	32 x 152	26.5	735	25-33	50	110-140	18-30	D (C)
	32 x 160	26.5	735	25-33	50	110-140	18-30	D (C)
BRK 70	28 x 160	25	760	23-31	50	110-125	18-30	D (C)
	32 x 152	25	760	23-31	50	110-125	18-30	D (C)
	32 x 160	25	760	23-31	50	110-125	18-30	D (C)
BRK 70 VR	28 x 160	29.5	765	23-31	50	110-145	18-30	D (C)
	32 x 152	29.5	765	23-31	50	110-145	18-30	D (C)
	32 x 160	29.5	765	23-31	50	110-145	18-30	D (C)
BRK 70 HBP	32 x 152	25	760	23-31	50	110-145	18-30	D (C)
BRK 70 VR HBP	28 x 152	29.5	765	23-31	50	110-145	18-30	D (C)
	28 x 160	29.5	765	23-31	50	110-145	18-30	D (C)
	32 x 152	29.5	765	23-31	50	110-145	18-30	D (C)
	32 x 160	29.5	765	23-31	50	110-145	18-30	D (C)
BRK 95	32 x 152	31.5	760	18-23	50	110-125	28-40	D (E)
	32 x 160	31.5	760	18-23	50	110-125	28-40	D (E)
BRK 95 VR	32 x 152	36	765	18-23	50	110-125	28-40	D (E)
	32 x 160	36	765	18-23	50	110-125	28-40	D (E)
BRK 95 HBP	28 x 152	31.5	760	18	50	110-140	28-30	D

BRK type	Maximum hydraulic return line pressure (Bar)	Maximum relief valve setting (Bar)	Minimum relief valve settings (Bar)
BRK 25 D, BRK 40, BRK 40 VR	10	172	140
BRK 55, BRK 55 VR, BRK 70, BRK 70 VR, BRK 95, BRK 95 VR	15	172	140
BRK 55 HBP, 55 VR HBP, BRK 70 HBP, BRK 70 VR HBP	35	172	140
BRK 95 HBP	20	172	140

	Shank dimension (in.)	Weight (lb)	Length (in.)	Impact freq. (Hz)	Accumulator pressure (psi)	Operating pressure (psi)	Flow rate (gal/min)	EHTMA Category
BRK 25 D	7/8 x 3 1/4	27.8	23.6	40	600	1000-1300	5-6	C
BRK 40	1 x 4 1/4	38.5	25.2	27	600	1380-1600	5-6	C
	1 1/8 x 6 1/4	42	27.2	27	600	1380-1600	5-6	C
	1 1/4 x 6	42	27.2	27	600	1380-1600	5-6	C
	1 1/4 x 6 1/4	42	27.2	27	600	1380-1600	5-6	C
BRK 40 VR	1 x 4 1/4	46.5	25.6	27	600	1380-1600	5-6	C
	1 1/4 x 6	52	27.5	27	600	1380-1600	5-6	C
	1 1/4 x 6 1/4	52	27.5	27	600	1380-1600	5-6	C
	1 1/8 x 6	52	27.5	27	600	1380-1600	5-6	C
BRK 55	1 x 4 1/4	45	26.7	25-33	700	1600-1800	5-8	D (C)
	1 1/8 x 6 1/4	48.5	28.7	25-33	700	1600-1800	5-8	D (C)
	1 1/4 x 6	48.5	28.7	25-33	700	1600-1800	5-8	D (C)
	1 1/4 x 6 1/4	48.5	28.7	25-33	700	1600-1800	5-8	D (C)
BRK 55 VR	1 x 4 1/4	55	27.2	25-33	700	1600-1800	5-8	D (C)

	Shank dimension (in.)	Weight (lb)	Length (in.)	Impact freq. (Hz)	Accumulator pressure (psi)	Operating pressure (psi)	Flow rate (gal/min)	EHTMA Category
	1 ¼ x 6	58.5	29	25-33	700	1600-1800	5-8	D (C)
	1 ¼ x 6 ¼	58.5	29	25-33	700	1600-1800	5-8	D (C)
	1 ½ x 6 ¼	58.5	29	25-33	700	1600-1800	5-8	D (C)
BRK 55 HBP	1 x 4 ¼	45	26.7	25-33	700	1600-2000	5-8	D (C)
	1 ½ x 6	48.5	28.7	25-33	700	1600-2000	5-8	D (C)
	1 ¼ x 6	48.5	28.7	25-33	700	1600-2000	5-8	D (C)
BRK 55 VR HBP	1 x 4 ¼	55	27.2	25-33	700	1600-2000	5-8	D (C)
	1 ½ x 6	58.5	29	25-33	700	1600-2000	5-8	D (C)
	1 ½ x 6 ¼	58.5	29	25-33	700	1600-2000	5-8	D (C)
	1 ¼ x 6	58.5	29	25-33	700	1600-2000	5-8	D (C)
	1 ¼ x 6 ¼	58.5	29	25-33	700	1600-2000	5-8	D (C)
BRK 70	1 ½ x 6 ¼	55	30	23-31	700	1600-1800	5-8	D (C)
	1 ¼ x 6	55	30	23-31	700	1600-1800	5-8	D (C)
	1 ¼ x 6 ¼	55	30	23-31	700	1600-1800	5-8	D (C)
BRK 70 VR	1 ¼ x 6	65	30.1	23-31	700	1600-1800	5-8	D (C)
	1 ½ x 6 ¼	65	30.1	23-31	700	1600-1800	5-8	D (C)
	1 ¼ x 6 ¼	65	30.1	23-31	700	1600-1800	5-8	D (C)
BRK 70 HBP	1 ¼ x 6	55	30	23-31	700	1600-1800	5-8	D (C)
BRK 70 VR HBP	1 ½ x 6	55	30	23-31	700	1600-2100	5-8	D (C)
	1 ½ x 6 ¼	55	30	23-31	700	1600-2100	5-8	D (C)
	1 ¼ x 6	55	30	23-31	700	1600-2100	5-8	D (C)
	1 ¼ x 6 ¼	55	30	23-31	700	1600-2100	5-8	D (C)
BRK 95	1 ¼ x 6	69.5	30	18-23	700	1600-1800	7-11	D (E)
	1 ¼ x 6 ¼	69.5	30	18-23	700	1600-1800	7-11	D (E)
BRK 95 VR	1 ¼ x 6	79.5	30.1	18-23	700	1600-1800	7-11	D (E)
	1 ¼ x 6 ¼	79.5	30.1	18-23	700	1600-1800	7-11	D (E)
BRK 95 HBP	1 ½ x 6	69.5	30	18	700	1600-2000	8	D

BRK type	Maximum hydraulic return line pressure (psi)	Maximum relief valve setting (psi)	Minimum relief valve settings (psi)
BRK 25 D, BRK 40, BRK 40 VR	145	2500	2000
BRK 55, BRK 55 VR, BRK 70, BRK 70 VR, BRK 95, BRK 95 VR	200	2500	2000
BRK 55 HBP, 55 VR HBP, BRK 70 HBP, BRK 70 VR HBP	500	2500	2000
BRK 95 HBP	290	2500	2000

## Noise and vibration declaration statement

Guaranteed sound power level **L<sub>w</sub>** according to EN ISO 3744 in accordance with directive 2000/14/EC.

Sound pressure level **L<sub>p</sub>** according to EN ISO 11203.

Vibration value **A** and uncertainty **B** determined according to EN ISO 28927-10. See table "Noise and vibration data" for the values of A, B, etc.

These declared values were obtained by laboratory type testing in accordance with the stated directive or standards and are suitable for comparison with the declared values of other tools tested in accordance with the same directive or standards. These declared values are not suitable for use in risk assessments and values measured in individual work places may be higher. The actual exposure values and risk of harm experienced by an individual user are unique and depend upon the way the user works, in what material the machine is used, as well as upon the exposure time and the physical condition of the user, and the condition of the machine.

We, Atlas Copco Construction Tools AB, cannot be held liable for the consequences of using the declared values, instead of values reflecting the actual exposure, in an individual risk assessment in a work place situation over which we have no control.

This tool may cause hand-arm vibration syndrome if its use is not adequately managed. An EU guide to managing hand-arm vibration can be found at

<http://www.humanvibration.com/humanvibration/EU/VIBGUIDE.html>

We recommend a programme of health surveillance to detect early symptoms which may relate to vibration exposure, so that management procedures can be modified to help prevent future impairment.

## Noise and vibration data

Type	Noise			Vibration	
	Sound pressure	Sound power		Three axes values	
	Declared values			Declared values	
	EN ISO 11203	2000/14/EC		EN ISO 28927-10	
	<b>L<sub>p</sub></b> r=1m dB(A) rel 20µPa	<b>K</b> uncertainty factor dB(A)	<b>L<sub>w</sub></b> guaranteed dB(A) rel 1pW	<b>A</b> m/s <sup>2</sup> value	<b>B</b> m/s <sup>2</sup> spreads
BRK 25 D (Hex 25x82.5, 20 lpm)	93	1.9	105	16.5	2.1
BRK 40 (Hex 25x108, 20 lpm )	93	1.6	107	15.1	2.0
BRK 40 (Hex 28x160, 20 lpm )	93	1.6	107	14.9	2.1
BRK 40 (Hex 32x152, 20 lpm )	93	1.6	107	14.9	2.1
BRK 40 (Hex 32x160, 20 lpm )	93	1.6	107	14.9	2.1
BRK 40 VR (Hex 25x108, 20 lpm)	93	1.6	107	5.0	1.0
BRK 40 VR (Hex 28x152, 20 lpm)	93	1.6	107	5.0	1.0
BRK 40 VR (Hex 32x152, 20 lpm)	93	1.6	107	5.3	1.0
BRK 40 VR (Hex 32x160, 20 lpm)	93	1.6	107	5.3	1.0
BRK 55 (Hex 25x108, 20 lpm )	94	2.1	107	18.1	2.3
BRK 55 (Hex 25x108, 30 lpm )	94	2.1	107	20.4	2.5
BRK 55 (Hex 28x160, 20 lpm )	94	2.1	107	16.6	2.1
BRK 55 (Hex 28x160, 30 lpm )	94	2.1	107	18.6	2.3
BRK 55 (Hex 32x152, 20 lpm )	94	2.1	107	16.6	2.1
BRK 55 (Hex 32x152, 30 lpm )	94	2.1	107	18.6	2.3
BRK 55 (Hex 32x160, 20 lpm )	94	2.1	107	16.6	2.1
BRK 55 (Hex 32x160, 30 lpm )	94	2.1	107	18.6	2.3
BRK 55 VR (Hex 25x108, 20 lpm )	94	2.1	107	4.8	1.0
BRK 55 VR (Hex 25x108, 30 lpm )	94	2.1	107	5.1	1.0
BRK 55 VR (Hex 28x160, 20 lpm )	94	2.1	107	4.6	0.9
BRK 55 VR (Hex 28x160, 30 lpm )	94	2.1	107	5.4	1.0
BRK 55 VR (Hex 32x152, 20 lpm )	94	2.1	107	4.6	0.9
BRK 55 VR (Hex 32x152, 30 lpm )	94	2.1	107	5.4	1.0
BRK 55 VR (Hex 32x160, 20 lpm )	94	2.1	107	4.6	0.9
BRK 55 VR (Hex 32x160, 30 lpm )	94	2.1	107	5.4	1.0
BRK 55 HBP (Hex 25x108, 20 lpm)	94	2.1	107	17.4	2.7
BRK 55 HBP (Hex 25x108, 30 lpm)	94	2.1	107	17.4	2.7
BRK 55 HBP (Hex 28x152, 20 lpm)	94	2.1	107	17.4	2.7
BRK 55 HBP (Hex 28x152, 30 lpm)	94	2.1	107	17.4	2.7
BRK 55 HBP (Hex 32x152, 20 lpm)	94	2.1	107	17.4	2.7
BRK 55 HBP (Hex 32x152, 30 lpm)	94	2.1	107	17.4	2.7
BRK 55 VR HBP (Hex 25x108, 20 lpm)	94	2.1	107	4.9	1.0
BRK 55 VR HBP (Hex 25x108, 30 lpm)	94	2.1	107	5.2	1.0

Type	Noise			Vibration	
	Sound pressure	Sound power		Three axes values	
	Declared values			Declared values	
	EN ISO 11203	2000/14/EC		EN ISO 28927-10	
	<b>L<sub>p</sub></b> r=1m dB(A) rel 20µPa	<b>K</b> uncertainty factor dB(A)	<b>L<sub>w</sub></b> guaranteed dB(A) rel 1pW	<b>A</b> m/s <sup>2</sup> value	<b>B</b> m/s <sup>2</sup> spreads
BRK 55 VR HBP (Hex 28x152, 20 lpm)	94	2.1	107	4.9	1.0
BRK 55 VR HBP (Hex 28x152, 30 lpm)	94	2.1	107	5.2	1.0
BRK 55 VR HBP (Hex 28x160, 20 lpm)	94	2.1	107	4.9	1.0
BRK 55 VR HBP (Hex 28x160, 30 lpm)	94	2.1	107	5.2	1.0
BRK 55 VR HBP (Hex 32x152, 20 lpm)	94	2.1	107	4.9	1.0
BRK 55 VR HBP (Hex 32x152, 30 lpm)	94	2.1	107	5.2	1.0
BRK 55 VR HBP (Hex 32x160, 20 lpm)	94	2.1	107	4.9	1.0
BRK 55 VR HBP (Hex 32x160, 30 lpm)	94	2.1	107	5.2	1.0
BRK 70 (Hex 28x160, 20 lpm)	95	2.1	110	19.4	2.4
BRK 70 (Hex 28x160, 30 lpm)	95	2.1	110	18.2	2.3
BRK 70 (Hex 32x152, 20 lpm)	95	2.1	110	19.4	2.4
BRK 70 (Hex 32x152, 30 lpm)	95	2.1	110	18.2	2.3
BRK 70 (Hex 32x160, 20 lpm)	95	2.1	110	19.4	2.4
BRK 70 (Hex 32x160, 30 lpm)	95	2.1	110	18.2	2.3
BRK 70 VR (Hex 28x160, 20 lpm)	95	2.1	110	4.6	1.0
BRK 70 VR (Hex 28x160, 30 lpm)	95	2.1	110	6.0	1.1
BRK 70 VR (Hex 32x152, 20 lpm)	95	2.1	110	4.6	1.0
BRK 70 VR (Hex 32x152, 30 lpm)	95	2.1	110	6.0	1.1
BRK 70 VR (Hex 32x160, 20 lpm)	95	2.1	110	4.6	1.0
BRK 70 VR (Hex 32x160, 30 lpm)	95	2.1	110	6.0	1.1
BRK 70 HBP (Hex 32x152, 20 lpm)	95	2.1	110	18.6	2.3
BRK 70 HBP (Hex 32x152, 30 lpm)	95	2.1	110	18.1	3.1
BRK 70 HBP (Hex 28x152, 20 lpm)	95	2.1	110	18.6	2.3
BRK 70 HBP (Hex 28x152, 30 lpm)	95	2.1	110	18.1	3.1
BRK 70 VR HBP (Hex 28x152, 20 lpm)	95	2.1	110	5.5	1.0
BRK 70 VR HBP (Hex 28x152, 30 lpm)	95	2.1	110	5.8	1.0
BRK 70 VR HBP (Hex 28x160, 20 lpm)	95	2.1	110	5.5	1.0
BRK 70 VR HBP (Hex 28x160, 30 lpm)	95	2.1	110	5.8	1.0
BRK 70 VR HBP (Hex 32x152, 20 lpm)	95	2.1	110	5.5	1.0
BRK 70 VR HBP (Hex 32x152, 30 lpm)	95	2.1	110	5.8	1.0
BRK 70 VR HBP (Hex 32x160, 20 lpm)	95	2.1	110	5.5	1.0
BRK 70 VR HBP (Hex 32x160, 30 lpm)	95	2.1	110	5.8	1.0
BRK 95 (Hex 32x152, 30 lpm)	93	1.9	106	20.1	2.5
BRK 95 (Hex 32x152, 40 lpm)	93	1.9	106	19.7	2.4
BRK 95 (Hex 32x160, 30 lpm)	93	1.9	106	20.1	2.5

	Noise			Vibration	
	Sound pressure	Sound power		Three axes values	
	Declared values			Declared values	
	EN ISO 11203	2000/14/EC		EN ISO 28927-10	
Type	<b>L<sub>p</sub></b> r=1m dB(A) rel 20µPa	<b>K</b> uncertainty factor dB(A)	<b>L<sub>w</sub></b> guaranteed dB(A) rel 1pW	<b>A</b> m/s <sup>2</sup> value	<b>B</b> m/s <sup>2</sup> spreads
BRK 95 (Hex 32x160, 40 lpm)	93	1.9	106	19.7	2.4
BRK 95 VR (Hex 32x152, 30 lpm)	93	1.9	106	5.4	1.0
BRK 95 VR (Hex 32x152, 40 lpm)	93	1.9	106	6.3	1.1
BRK 95 VR (Hex 32x160, 30 lpm)	93	1.9	106	5.4	1.0
BRK 95 VR (Hex 32x160, 40 lpm)	93	1.9	106	6.3	1.1
BRK 95 HBP (Hex 28x152, 30 lpm)	93	1.9	106	20.1	2.5



# EC Declaration of Conformity

## EC Declaration of Conformity (EC Directive 2006/42/EC)

We, Atlas Copco Construction Tools AB, hereby declare that the machines listed below conform to the provisions of EC Directive 2006/42/EC (Machinery Directive) and 2000/14/EC (Noise Directive), and the harmonised standards mentioned below.

	Guaranteed sound power level [dB(A)]	Measured sound power level [dB(A)]
BRK 25 D	105	104
BRK 40	107	104
BRK 40 VR	107	104
BRK 55, BRK 55 HBP	107	105
BRK 55 VR, BRK 55 VR HBP	107	105
BRK 70, BRK 70 HBP	110	106
BRK 70 VR, BRK 70 VR HBP	110	106
BRK 95, BRK 95 HBP	106	104
BRK 95 VR	106	104

### Following harmonised standards were applied:

- ◆ EN ISO 11148-4

### Technical Documentation authorised representative:

Emil Alexandrov  
Atlas Copco Lifton EOOD  
7000 Rousse  
Bulgaria

### General Manager:

Nick Evans

### Manufacturer:

Atlas Copco Construction Tools AB  
105 23 Stockholm  
Sweden

### Place and date:

Rousse, 2012-05-24





